



**PNEUMATIC CUTTER MOD.  
Operating and maintenance manual**

**RAPIDCUT - 8 XL**

**CE**



## CONTENTS

	<b>Page</b>
COMPLIANCE CERTIFICATE	3
DIAGRAM OF PARTS	4
SAFETY MEASURES AND BLADE REPLACEMENT	5
TECHNICAL FEATURES AND MAINTENANCE	6
OTHER CUTTER MODELS	7

**COMPLIANCE CERTIFICATE**

S.C.C.L

**CONSTRUCCION DE MAQUINARIA**

C/JUPITER 47 NAVE 8 POL. IND. CAN PARELLADA 08228 TERRASSA  
BARCELONA  
TEL. 93 7834543 FAX. 93 7855910

DECLARES, ON ITS OWN RESPONSIBLY, THAT THIS  
SHEARS MOD. **RAPIDCUT** - 8 XL

ARE MANUFACTURED TO COMPLY WITH THE SAFETY  
AND ACCIDENT PREVENTION REQUIREMENTS OF THE  
COUNCIL DIRECTIVE 89/392/EEC AS WELL AS ANY FU-  
TURE MODIFICATIONS.

S.C.C.L

Juan Salvador  
DIR. FABRICA



Gil Salvador  
DIR. TECNICO



**SAFETY PRECAUTIONS  
WARNING**

For your own safety, please carefully read and follow all the safety precautions before attempting to operate the tool. These must be followed at all times to ensure safe operation.. Improper use can cause serious injury.

# ASSEMBLING THE CUTTER **RAPIDCUT-8 XL**

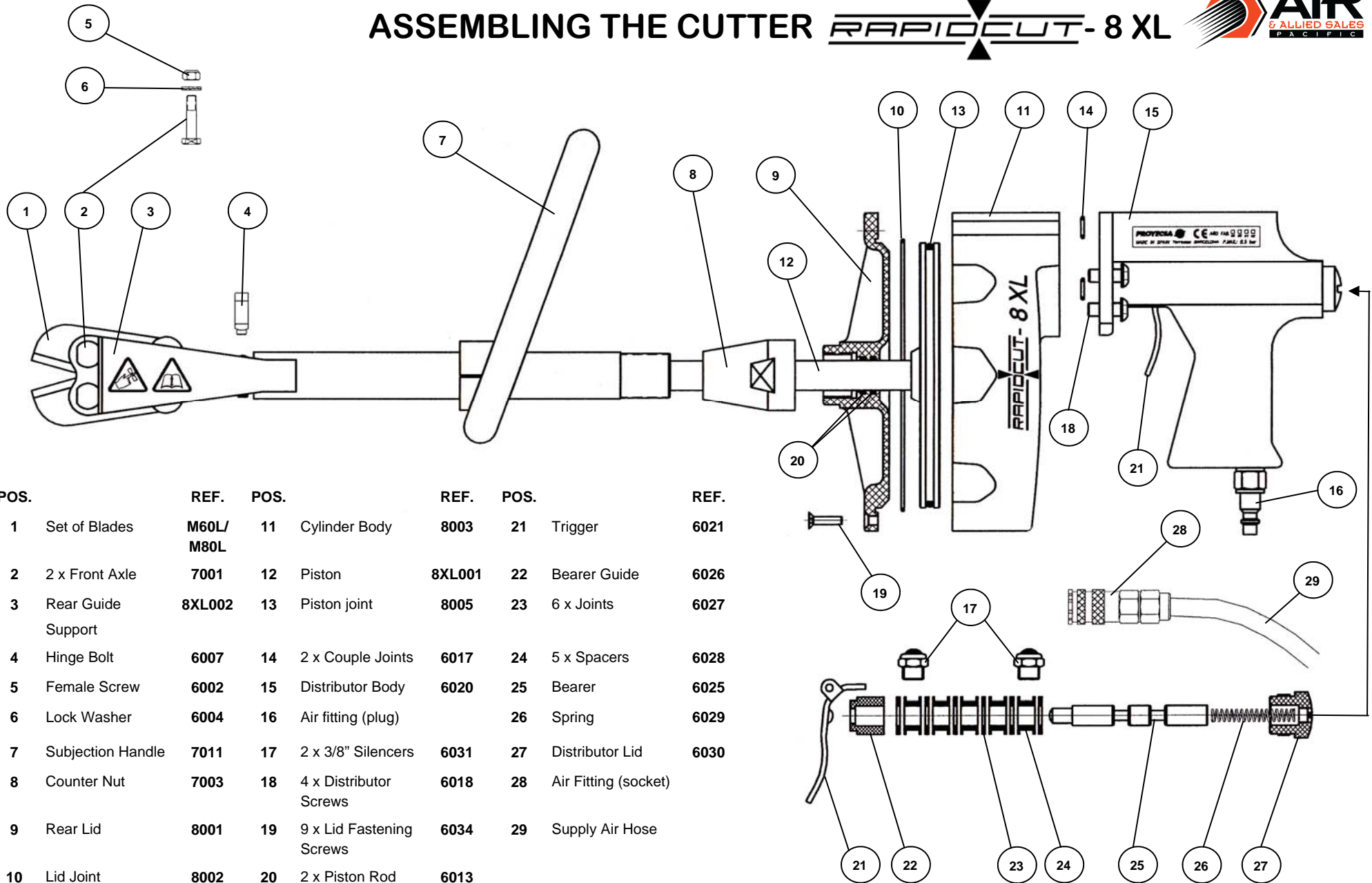

POS.	REF.	POS.	REF.	POS.	REF.
1	Set of Blades	<b>M60L/ M80L</b>	11	Cylinder Body	<b>8003</b>
2	2 x Front Axle	<b>7001</b>	12	Piston	<b>8XL001</b>
3	Rear Guide Support	<b>8XL002</b>	13	Piston joint	<b>8005</b>
4	Hinge Bolt	<b>6007</b>	14	2 x Couple Joints	<b>6017</b>
5	Female Screw	<b>6002</b>	15	Distributor Body	<b>6020</b>
6	Lock Washer	<b>6004</b>	16	Air fitting (plug)	
7	Subjection Handle	<b>7011</b>	17	2 x 3/8" Silencers	<b>6031</b>
8	Counter Nut	<b>7003</b>	18	4 x Distributor Screws	<b>6018</b>
9	Rear Lid	<b>8001</b>	19	9 x Lid Fastening Screws	<b>6034</b>
10	Lid Joint	<b>8002</b>	20	2 x Piston Rod Joints	<b>6013</b>
			21	Trigger	<b>6021</b>
			22	Bearer Guide	<b>6026</b>
			23	6 x Joints	<b>6027</b>
			24	5 x Spacers	<b>6028</b>
			25	Bearer	<b>6025</b>
			26	Spring	<b>6029</b>
			27	Distributor Lid	<b>6030</b>
			28	Air Fitting (socket)	
			29	Supply Air Hose	

# WARNING!!



**DISCONNECT FROM AIR SUPPLY BEFORE REPLACING BLADES**



**KEEP OUT OF REACH OF CHILDREN**



**NEVER CONNECT TO A PRESSURE HIGHTER THAN 8.5 bar**



**THE USE OF PROTECTING GOGGLES IS RECOMMENDED**

## PROPER USE

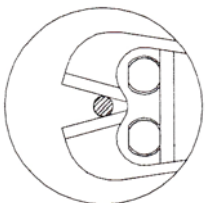

**YES**

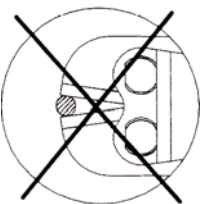

**NO!**

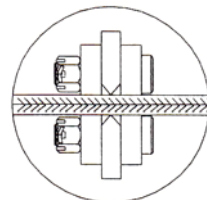

**YES**

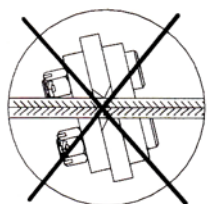

**NO!**

## BLADE REPLACEMENT



1—TO PREVENT ACCIDENTS KEEP AIR SUPPLY DISCONNECTED THROUGHOUT THE WHOLE BLADE RELACEMENT OPERATION

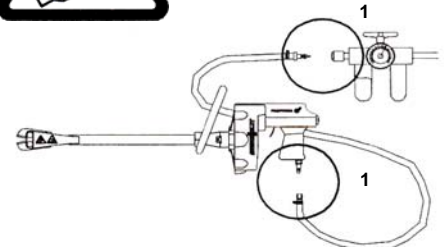

2—LOOSEN THE BOLTS AND REMOVE THE TWO HEAD AXLES, BY PUTTING IT ON A FLAT SURFACE AND HITTING THE THREAD AREA WITH A NYLON HAMMER, NOT TO DAMAGE THE THREAD.

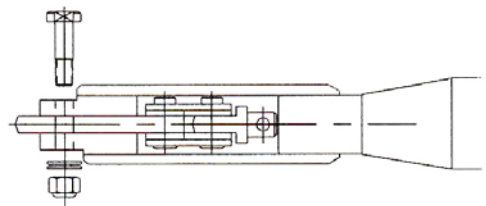

3—PULL THE TWO BLADES APART REMOVE THE BOLT FROM THE HINGE AND ASSEMBLE THE NEW BLADES IT IS ADVISABLE TO OIL ALL THE FRICTION AND TURNING AREAS DURING THIS OPERATION

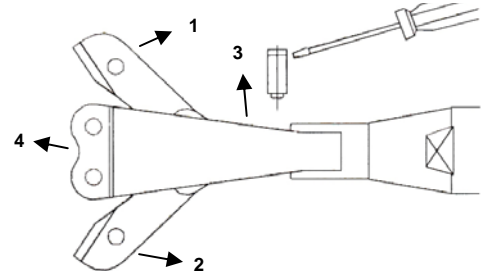

4—TIGHTEN THE FASTENING NUTS WITH AN APPROXIMATE TORQUE OF 14 Nm. IF A DYNAMOETRIC WRENCH IS NOT AVAILA-BLE, APPLY ABOUT 10 Kg. A CONVENTION-AL 12-13 mm. WRENCH

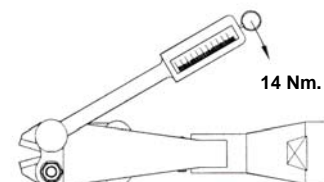

# TECHNICAL FEATURES

POWER SUPPLY.....	Filtered, lubricated air
CONSUMPTION.....	7 Lt./cut at 7 bar
MAXIMUM $\phi$ CUT.....	8 $\phi$ (Steel up to 70 Kg./mm <sup>2</sup> )
	5 $\phi$ (Steel up to 180 Kg./mm <sup>2</sup> )
SPEED.....	60 Cuts/minute
MAXIMUM PRESSURE.....	8.5 bar
MINIMUM PRESSURE.....	6 bar
WEIGHT.....	8.7 Kg.

## APPROPRIATE BLADE TYPE

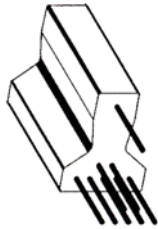

**MAX. 5 $\phi$**

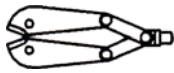

REF. M8OL  
For prestressed material  
Up to 180 Kg./mm<sup>2</sup>



**MAX. 8 $\phi$**

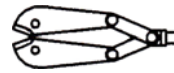

REF. M6OL  
For corrugated material  
Up to 70 Kg./mm<sup>2</sup>

## START-UP AND MAINTENANCE

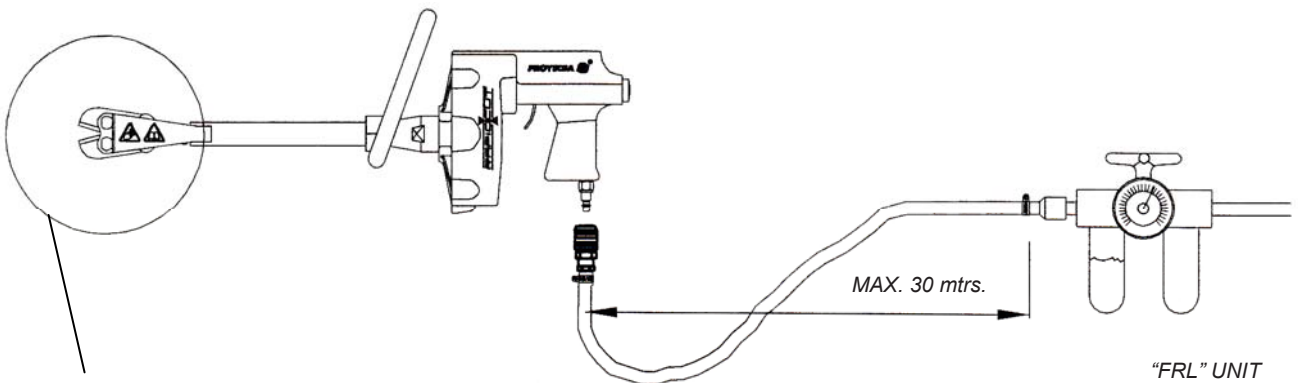

Lubricate blade head friction areas every 500 cuts. Dip it in lubricating oil and pull the trigger several times keeping the blades in the oil.  
**THIS WAY YOU WILL OBTAIN OPTIMUM PERFORMANCE OF THE BLADES DURING THEIR USEFUL LIFE.**

By installing a device to remove water, adjust pressure and lubricate air, the useful life of the body and guides of the cutter is remarkably lengthened.

# OTHER MODELS

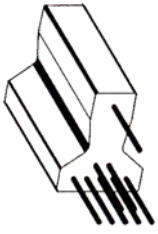

MAX. 4 $\phi$

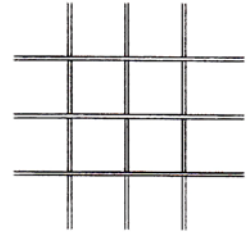
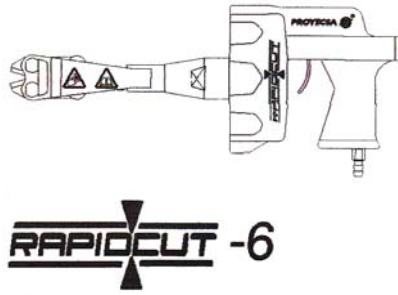

MAX. 6 $\phi$

WEIGHT.....3.2 Kg.

---

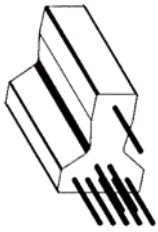

MAX. 7 $\phi$

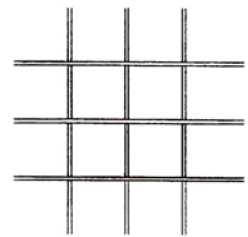
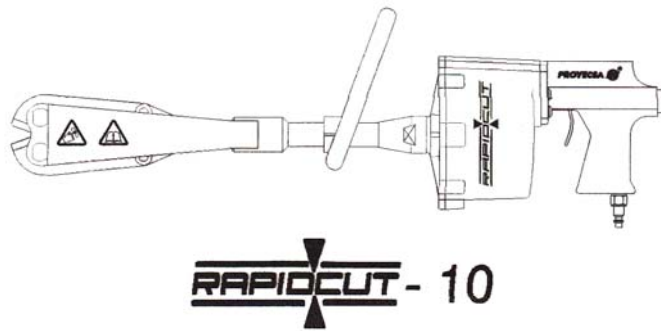

MAX. 10 $\phi$

WEIGHT.....8 Kg.

---

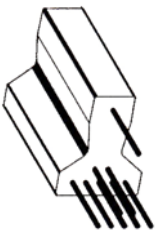

MAX. 8 $\phi$

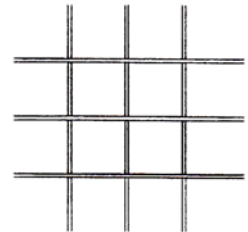
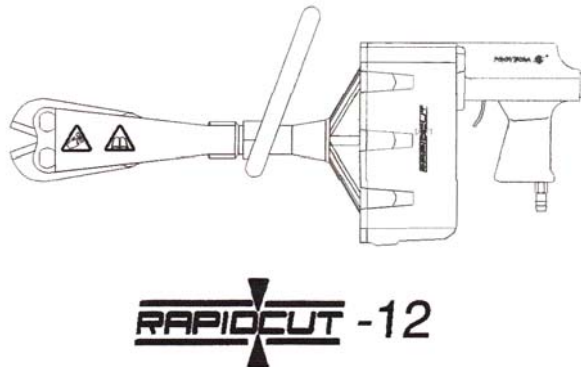

MAX. 12 $\phi$

WEIGHT.....10 Kg.

---

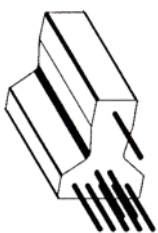

MAX. 9 $\phi$

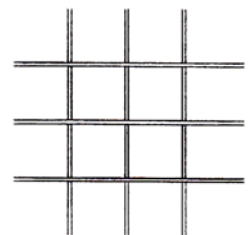
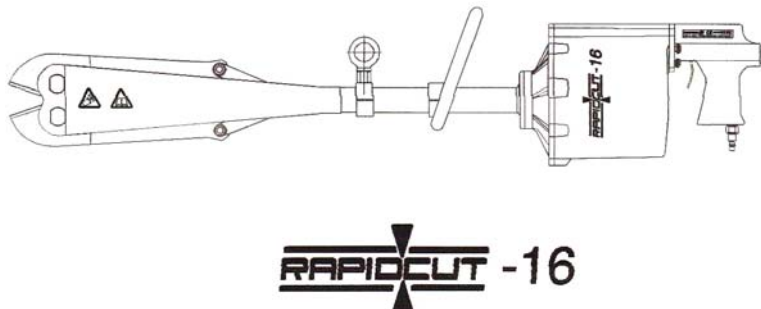

MAX. 16 $\phi$

WEIGHT.....18 Kg.

